



Dependable Products From People You Trust



PCS 340 Core Saturator

127-70: 115 Volt

127-70-1: 230 Volt

Instruction Manual

Updated 5/26/2026

Ver. 3

OFI Testing Equipment, Inc.

11302 Steeplecrest Dr. · Houston, Texas · 77065 · U.S.A.
Tele: 832.320.7300 · Fax: 713.880.9886 · www.ofite.com

©Copyright OFITE 2015

Table of Contents

Intro.....	2
Specifications	3
Components	3
Installation.....	4
Procedure.....	5
Maintenance.....	9
Warranty and Return Policy	10

Intro

The OFITE PCS 340 Core Saturator is designed to fully saturate a core sample before starting a permeability test. This reduces the time required to reach steady state conditions and increases the accuracy and reproducibility of the test results.

The Core Saturator includes a test cell, vacuum pump, air-driven pump, and saturation fluid reservoir. The vacuum pump removes air from the core sample prior to saturation. Then the air driven pump pulls saturation fluid from the reservoir and pressurizes the test cell.

Specifications

Maximum Pressure: 2,500 PSI (2.5 MPa)
Maximum Core Size: 3" Diameter × 24" Long
Air Requirement: 100 - 120 PSI (689.5 - 827.4 kPa)

Components

#127-70-020 Cell Body
#127-70-021 Cell Plug
#127-70-022 Lock Ring
#127-70-023 Bottom Cell Closure
#127-70-024 Handle
#127-70-026 Cell O-ring
#127-70-027 Cell Backup Ring
#127-70-028 Retaining Ring
#127-70-030 Vacuum Gauge
#120-910-022 Pressure Gauge
#120-00-030 Air Filter

Installation

1. Remove the unit from the crate and place it on a flat, stable surface.
2. Make sure all valves and the Vacuum Pump switch are OFF.
3. On the back of the unit connect an air supply (100 - 150 PSI) and drain line. Both connections are ¼" NPT.
4. Plug the unit into an appropriate power source.

Procedure

Before beginning the procedure, make sure all four valves and the Vacuum Pump switch are OFF.

1. Place the reservoir on the left-hand side of the unit and fill it with saturation fluid. Place the reservoir tube down into the saturation fluid.

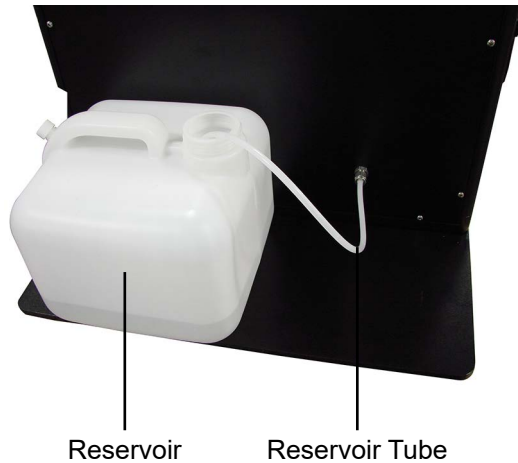

2. Lift the stop pin and rotate the test cell until it is horizontal. Release the stop pin to hold the cell in place.

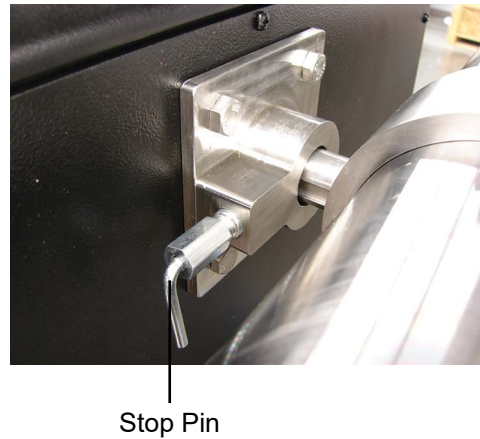

3. Screw the bottom cell cap into the bottom of the test cell. Tighten it hand tight.

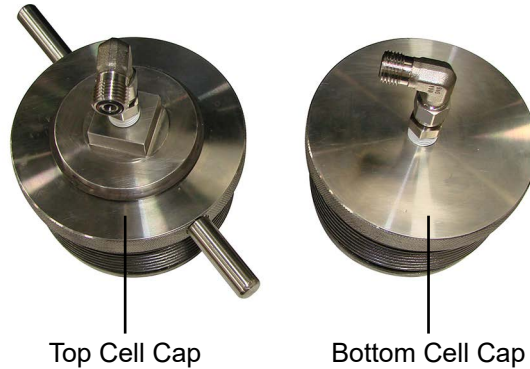

4. Place the core sample on the provided tray and slide it all the way into the test cell.
5. Screw the top cell cap into the top of the test cell. Tighten it hand tight.
6. Lift the stop pin and rotate the test cell until it is vertical. Release the stop pin to hold the cell in place.
7. Install the supplied high-pressure lines into the quick-connect fittings on the unit cabinet.

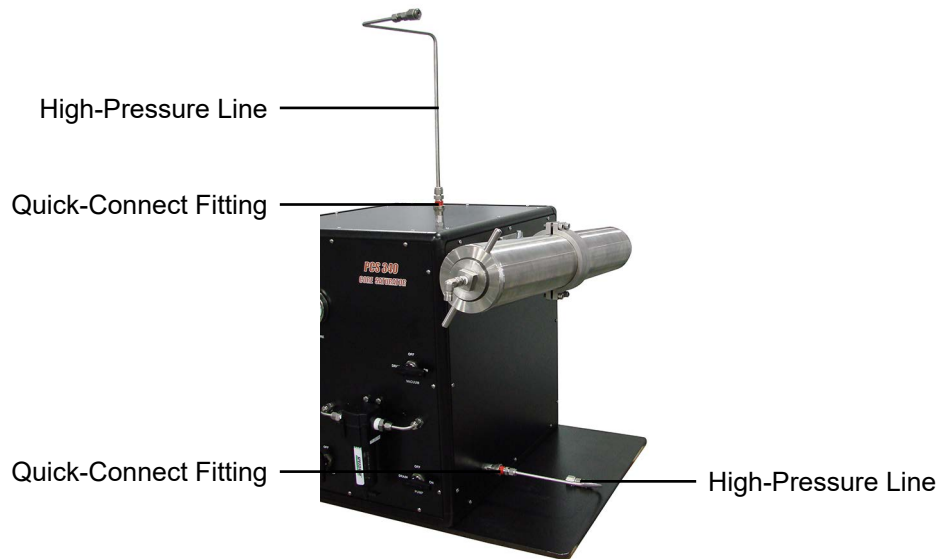

8. The port on the bottom cell cap should already be turned to the correct angle to line up with the high-pressure line. However, on the top cap, the port may need to be rotated to line up with the high-pressure line. If so, use an adjustable wrench to turn the inner portion of the cap so that the port is at the correct angle to line up with the high-pressure line.
9. Connect the two cell cap ports to the high pressure lines. Tighten the fittings finger tight.

10. Turn the Vacuum Valve to ON.
11. Turn the Vacuum Pump switch ON. Wait for the vacuum pressure to stabilize (approximately 20 - 26 inHg). This will remove the air from the pore spaces in the core.
12. Once the vacuum pressure has stabilized, turn the Reservoir and Pump valves ON. This will allow saturation fluid from the reservoir to fill the test cell.
13. Watch the filter on the front of the cabinet. When saturation fluid starts to collect in the filter, immediately turn the Vacuum valve and Vacuum Pump switch OFF. This will prevent the fluid from reaching the vacuum pump.



To prevent damage to the vacuum pump, make sure the Vacuum valve is closed and the Vacuum Pump switch is turned off before fluid is able to reach the pump.

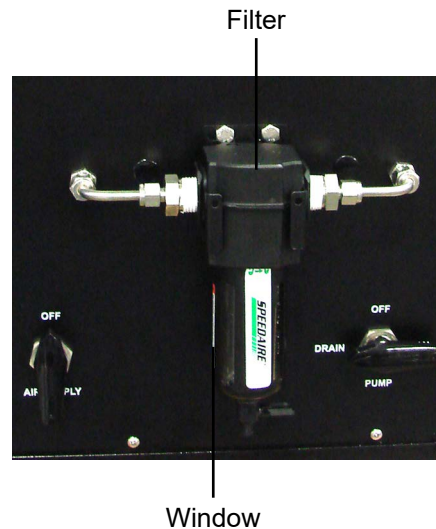

14. Turn the Air Supply valve ON.
15. Turn the regulator clockwise to apply pressure to the test cell.
16. When the procedure is complete, turn the regulator counter-clockwise to stop applying pressure to the cell.
17. Turn the Air Supply and Reservoir valves OFF.
18. Slowly turn the Pump valve to DRAIN. Wait for the pressure in the cell to drop to zero.
19. Turn the Vacuum valve to DRAIN.



Do not turn the Vacuum valve to DRAIN until all pressure has been released from the cell.

20. When the test cell has completely drained, disconnect the high-pressure fittings from the cell caps.
21. Rotate the cell back to the horizontal position.
22. Unscrew the top cell cap.
23. Remove the core sample.
24. Remove the bottom cell cap.
25. Clean the inside of the test cell with water and an appropriate solvent.

Maintenance

1. Periodically inspect the o-rings and backup rings on the cell caps. Also inspect the o-ring in the cell cap fitting. Replace any that show signs of damage or wear.

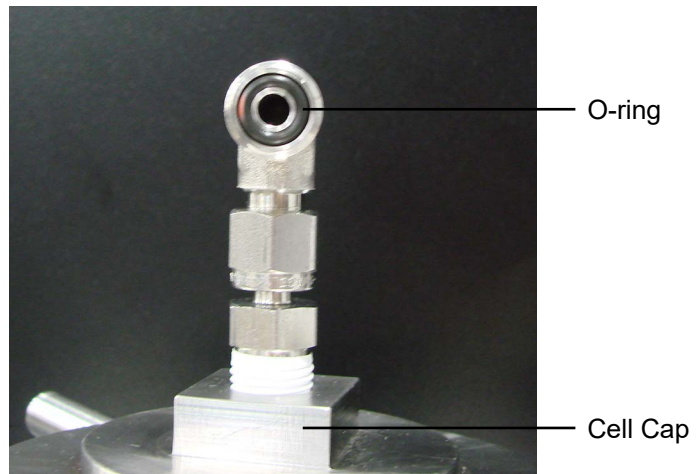

2. The filter on the front of the unit will collect fluid during a test. The filter reservoir should be emptied before it is completely full. To do this, simply turn the reservoir and pull down. Pour the fluid out and replace the reservoir.
3. Inside the unit cabinet is a second filter for the incoming air line. This filter also collects water over time and should be emptied. To do this, press the button on the bottom of the filter. A paper towel can be used to soak up any water.

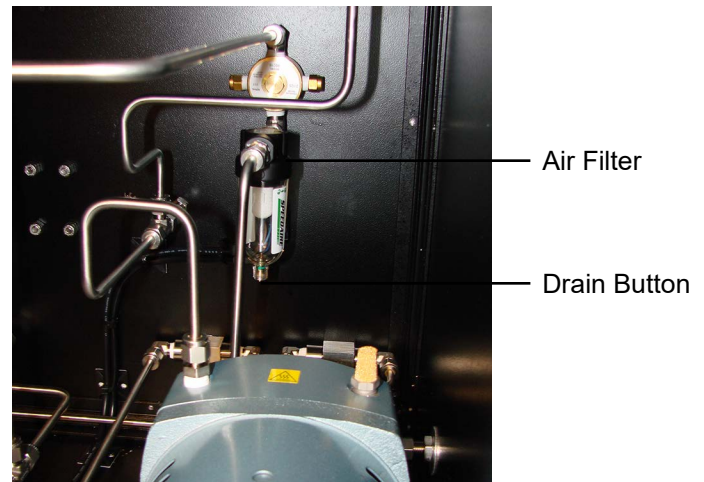

Warranty and Return Policy

Warranty:

OFI Testing Equipment, Inc. (OFITE) warrants that the products shall be free from liens and defects in title, and shall conform in all respects to the terms of the sales order and the specifications applicable to the products. All products shall be furnished subject to OFITE's standard manufacturing variations and practices. Unless the warranty period is otherwise extended in writing, the following warranty shall apply: if, at any time prior to twelve (12) months from the date of invoice, the products, or any part thereof, do not conform to these warranties or to the specifications applicable thereto, and OFITE is so notified in writing upon discovery, OFITE shall promptly repair or replace the defective products. Notwithstanding the foregoing, OFITE's warranty obligations shall not extend to any use by the buyer of the products in conditions more severe than OFITE's recommendations, nor to any defects which were visually observable by the buyer but which are not promptly brought to OFITE's attention.

In the event that the buyer has purchased installation and commissioning services on applicable products, the above warranty shall extend for an additional period of twelve (12) months from the date of the original warranty expiration for such products.

In the event that OFITE is requested to provide customized research and development for the buyer, OFITE shall use its best efforts but makes no guarantees to the buyer that any products will be provided.

OFITE makes no other warranties or guarantees to the buyer, either express or implied, and the warranties provided in this clause shall be exclusive of any other warranties including ANY IMPLIED OR STATUTORY WARRANTIES OF FITNESS FOR PURPOSE, MERCHANTABILITY, AND OTHER STATUTORY REMEDIES WHICH ARE WAIVED.

This limited warranty does not cover any losses or damages that occur as a result of:

- Improper installation or maintenance of the products
- Misuse
- Neglect
- Adjustment by non-authorized sources
- Improper environment
- Excessive or inadequate heating or air conditioning or electrical power failures, surges, or other irregularities
- Equipment, products, or material not manufactured by OFITE
- Firmware or hardware that have been modified or altered by a third party
- Consumable parts (bearings, accessories, etc.)

Returns and Repairs:

Items being returned must be carefully packaged to prevent damage in shipment and insured against possible damage or loss. OFITE will not be responsible for equipment damaged due to insufficient packaging.

Any non-defective items returned to OFITE within ninety (90) days of invoice are subject to a 15% restocking fee. Items returned must be received by OFITE in original condition for it to be accepted. Reagents and special order items will not be accepted for return or refund.

OFITE employs experienced personnel to service and repair equipment manufactured by us, as well as other companies. To help expedite the repair process, please include a repair form with all equipment sent to OFITE for repair. Be sure to include your name, company name, phone number, email address, detailed description of work to be done, purchase order number, and a shipping address for returning the equipment. All repairs performed as "repair as needed" are subject to the ninety (90) day limited warranty. All "Certified Repairs" are subject to the twelve (12) month limited warranty.

Returns and potential warranty repairs require a Return Material Authorization (RMA) number. An RMA form is available from your sales or service representative.

Please ship all equipment (with the RMA number for returns or warranty repairs) to the following address:

OFI Testing Equipment, Inc.
Attn: Repair Department
11302 Steeplecrest Dr.
Houston, TX 77065
USA

OFITE also offers competitive service contracts for repairing and/or maintaining your lab equipment, including equipment from other manufacturers. For more information about our technical support and repair services, please contact techservice@ofite.com.